

# Request for Quotations (RFQ)

## RFQ No: GH-04-2016

---

**RFQ Title:** Procurement of Peanut Roasting Equipment in Ghana

**Schedule:**

**Issuance Date of RFQ:** March 2, 2016  
**Questions Due:** March 11, 2016 by 12:00 EST  
**Answers Released:** March 14, 2016 by 17:00 EST  
**Quotation Due Date:** March 31, 2016 by 17:00 EST\*  
**Tentative Contract Start Date:** May 1, 2016

*\*Late offers will not be accepted*

The Strengthening Partnerships, Results and Innovations in Nutrition Globally (SPRING) Project, implemented by JSI Research & Training Institute, Inc. (JSI), is soliciting quotations to supply the above RFQ title as described in the attached Product Specifications, Annex 1. The SPRING Project is funded by the U.S. Agency for International Development (USAID) and is subject to applicable U.S. federal regulations and provisions.

Please submit your most competitive quotation in English in accordance with the attached instructions. Any contract issued as a result of this RFQ will be subject to all instructions, certifications, terms and conditions, and specifications (see Annex 1) included in this RFQ. This document is a request for quotations only and in no way obligates JSI or USAID to make any award.

All quotations, inquiries, and correspondence pertaining to this solicitation are to be directed to the attention of:

JSI Research & Training Institute Inc.  
Attn: Ryan Macabasco, SPRING Contracts & Finance Manager  
1616 Fort Myer Drive, 16<sup>th</sup> Floor  
Arlington, VA, USA, 22209  
Email: [procurement@spring-nutrition.org](mailto:procurement@spring-nutrition.org)

**Offers must be submitted by email with the subject "RFQ No.: GH-04-2016"**

### **STATEMENT OF CONFIDENTIALITY**

All information within this RFQ, regardless of the communication form, is given in absolute confidence and may not be disclosed without written permission from JSI Research & Training Institute, Inc.
---

## **GENERAL**

The Strengthening Partnerships, Results, and Innovations in Nutrition Globally (SPRING) project is a five-year USAID-funded Cooperative Agreement to strengthen global and country efforts to scale up high-impact nutrition practices and policies and improve maternal and child nutrition outcomes. The project is managed by JSI Research & Training Institute, Inc., with partners Helen Keller International, The Manoff Group, Save the Children Federation, Inc., and the International Food Policy Research Institute.

## **INSTRUCTIONS TO OFFERORS**

### **1. DEFINITIONS**

**Offeror:** The individual or firm providing quotations for the supplies or equipment requested under this RFQ.

**Contractor:** The individual or firm awarded the services requested under the RFQ in the form of a subcontract.

### **2. DELIVERY ADDRESS**

Goods requested shall be delivered to the address specified below:

**Consignee:**

USAID Executive Office  
No. 24 Fourth Circular Road  
Cantonments, Accra, Ghana

**Final Delivery Recipient:**

USAID SPRING Ghana Project  
c/o USAID Ghana  
24 Fourth Circular Road  
Cantonment, Accra, Ghana  
Attn: Bernard Kodzo Henyo  
+233 209 065 295

### **3. QUOTATION REQUIREMENTS**

No more than 1 (one) quotation may be submitted by each Offeror. **Offerors may quote for individual or all items listed in this RFQ.**

Offerors are encouraged to read the solicitation in its entirety and ensure that their quotation addresses all of the items cited in the instructions and meets the selection criteria. All quotations must be submitted by the deadline established on the cover page of this RFQ. Quotations submitted after the closing date and time will not be considered.

Receipt of a quotation to this request does not constitute an award or commitment on behalf of JSI or the United States Government, nor does it commit JSI or the US Government to reimburse any costs incurred in the preparation and submission of a quotation. JSI reserve the right not to make any award as a result of this solicitation.

Quotations should be developed in accordance with the requirements stated in this RFQ, including this section and Annex 1, Product Specifications.

Quotations must be provided on vendor letterhead and include the following required information:

- Specifications listed in Annex 1
- Delivered At Place (DAP) Incoterms, *air* freight and delivery to PPB in Kumasi, Ghana, and
- Delivered At Place (DAP) Incoterms, *ocean* freight and delivery to PPB in Kumasi, Ghana
- Offeror's product code, detailed manufacturer product description and specifications;
- Manufacturer's origin (Manufacturer name, Town, and Country);
- Estimated lead time for production;
- Estimated delivery to the final location(s) for each product;
- Unit Price and Total Price in US Dollars (\$)
- Transportation, transit insurance (110% of delivered price of goods), pre-delivery inspection, sample/ testing (if required) cost breakdowns must each be quoted in separate line items, as applicable.
- Proof of compliance with the technical specifications stated in the RFQ;
- Proof of QA, cMGP, FDA/SRA certification, CE-mark, or ISO certification when applicable
- Total number of cartons / pallets
- Gross weight (kg) and dimensions (cm) of each carton / pallet
- Total gross weight (kg) and total cube (m3)
- Warranty information, including warranty period
- Validity period of quotation, no less than the offer validity period established below (90 days)

**Capabilities and Past Performance:**

In addition to the quotation requirements listed above, the Offeror must submit a Capabilities Statement and complete the attached Past Performance Information table (see Attachment 2).

The **Capabilities Statement** shall not to exceed three (3) pages in length and will be used to evaluate the offeror's organizational, financial, and technical capacity, in relation to the Product Specifications in Annex 1. The Capabilities Statement must include, but is not limited to: size of the agency, financial resources available to complete this work, staffing competencies and capabilities, past experience performing similar work with other organizations, and a company profile and/or brochure.

Additionally, the Offeror must complete and submit the **Past Performance Information** table (see Annex 3).

The Capabilities Statement and Past Performance Information table will be used to establish the Offeror as a responsible contractor.

### **Pre-Shipment Testing**

JSI or its delegated entity shall conduct both factory acceptance testing (FAT), as well as site acceptance test (SAT). During each round of testing, all equipment shall meet performance criteria specified in Annex 1, Product Specifications.

## **4. FINANCIAL RESPONSIBILITY**

Offerors must include in the Capabilities Statement that they have the financial viability and resources to complete the proposed activities within the period of performance and under the terms of payment outlined below. JSI reserves the right to request and review the latest financial statements and audit reports of the Offeror as part of the basis of the award.

## **5. OFFER VALIDITY**

The Offeror's quotation must remain valid for not less than **90 calendar days from due date of receipt of quotations**. In exceptional circumstances, prior to expiry of the original offer validity period, JSI may request that the Offeror extend the period of validity for a specified additional period.

## **6. CURRENCY**

Prices shall be stated in USD (\$).

## **7. NEGOTIATIONS**

The Offeror's most competitive quotation is requested. It is anticipated that any award issued will be made solely on the basis of an Offeror's quotation. However, the Project reserves the right to request responses to additional questions which would help in negotiating and awarding a contract. The Project also reserves the right to conduct negotiations prior to the award of a contract. In the event that an agreement cannot be reached with an Offeror the Project will enter into negotiations with alternate Offerors for the purpose of awarding a contract without any obligation to previously considered Offerors.

## **8. REJECTION OF QUOTATIONS**

The Project reserves the right to reject any and all quotations received, or to negotiate separately with any and all competing Offerors. Offerors whose quotations are not selected will be notified in writing.

## **9. INCURRING COSTS**

The Project is not liable for any cost incurred by Offerors during preparation, submission, or negotiation of an award for this RFQ. The costs are solely the responsibility of the Offeror.

## **10. CANCELLATION**

The Project may cancel this RFQ without any cost or obligation at any time until issuance of a contract.

## **11. EVALUATION CRITERIA**

Quotations will be evaluated first to ensure that they meet all mandatory requirements as listed above under "Quotation Requirements". Quotations that fail to meet these requirements may receive no further consideration. A non-responsive proposal to any element may be eliminated from consideration.

For the purpose of selection, the evaluation will be based on an integrated assessment of the quotations, including, but not limited to, the following:

- Quality, reputation and performance of supplier in a global or local environment. JSI requires an opportunity to evaluate samples for testing, as needed.
- Thoroughness of quotation preparation.
- Demonstrated excellence in service, support and warranties on a global and local context.
- Competitive pricing with the capacity to provide advance and locked pricing.
- Ability to deliver the requested goods/and or services by the required date(s).
- Capability of supplier to identify all elements leading to understanding of the actual landed costs by region/country and establish lead-time and fulfillment objectives.
- Demonstrated ability to provide International account coordination and consolidated purchase reporting for JSI management while enabling use of local accounts, support and services in our global areas of operation.

JSI reserves the right to make an award based solely on the quotations received, to modify the requirements prior to awarding, or to negotiate further with one or more suppliers. JSI reserves the right to award a contract to the supplier who, in their sole opinion, provides the best combination of cost and quality benefits.

## **12. CONTRACT AWARD**

The contracting document will be a Fixed Price Contract to be awarded once a contractor has been selected, whose quotation is most advantageous, cost and other factors considered. The

awarded contract will include a statement of the total fixed price; the scope of work with stated deliverables and due dates; required provisions; and invoicing information. Please be advised that under a fixed price contract the work must be completed within the specified total price. Any expenses incurred in excess of the agreed upon amount in the contract will be the responsibility of the contractor and not that of JSI or USAID.

JSI reserves the right to issue a contract based on the initial evaluation of offers without discussion. JSI may choose to award a contract for part of the goods specified in Annex 1. JSI may choose to award a contract to more than one offeror for specific goods in the RFQ. Therefore, the Offeror is duly advised to provide its most competitive and realistic cost quotations to cover all foreseeable expenses related to the tasks outlined in the Product Specifications in Annex 1.

### **13. CERTIFICATIONS**

The quotation shall be accompanied by all required Certifications in Annex 4, signed by an authorized official of the Offeror.

### **14. KEY CLAUSES AND PROVISIONS**

The following key clauses and provisions will be incorporated into the contract awarded as a result of this solicitation. The list is not comprehensive but provides Offeror's with the key provisions and clauses to be included.

#### **a) Payment**

JSI policy prohibits advance payments. Payments may negotiated per deliverable required. Payments will be made on the following basis:

- The contractor will submit an invoice for payment after being notified of receipt and acceptance of the deliverable(s) by the JSI Activity Manager. Acceptance is predicated upon the compliance of the goods with the specifications set forth in the contract.
- The contractor will be paid the fixed amount as stated on the contract. A contractor should expect a payment schedule of 30/60/10, 30% down payment, 60% at FAT (Factory Acceptance Testing) at ready to ship, and 10% at Site Acceptance Testing. JSI payment cycle is net 30 days upon receipt of invoice.
- Should the contractor require payment along other terms and conditions, these will need to be negotiated with JSI prior to final award and issuance of the contract. Full cooperation with JSI in meeting the terms and conditions of payment will be given the highest consideration.

#### **b) Executive Order on Terrorist Financing**

The contractor must not engage in transactions with, or provide resources or support to, individuals and organizations associated with terrorism, including those individuals or entities that appear on the Specially Designated Nationals and Blocked Persons List maintained by the U.S. Treasury (online at: <http://www.treasury.gov/resource-center/sanctions/SDN-List/Pages/default.aspx>) or the United Nations Security designation list (online at: [http://www.un.org/sc/committees/1267/aq\\_sanctions\\_list.shtml](http://www.un.org/sc/committees/1267/aq_sanctions_list.shtml)).

**c) Debarment, Suspension, Ineligibility, and Voluntary Exclusion**

The vendor certifies that neither it nor its principals is presently excluded or disqualified from participation in this transaction by any US Government federal department or agency.

**d) Standard General Contract Terms and Conditions for USAID-Financed, International Supply of Goods (see Annex 5)**

**e) USAID Standard Provisions for U.S. NGOs and other required USG Contract Provisions**  
(This document can be found at the SPRING Procurement Page at [www.spring-nutrition.org/spring-procurement](http://www.spring-nutrition.org/spring-procurement))

END CLAUSES

## Annex 1: List of Requirements for Equipment

---

### **General requirement notes (#1: Top Preference):**

- **Preference for non-food contact surfaces (including support structures):**
  - #1: Stainless steel
  - #2: Carbon Steel (must be coated, preferences below, #1 Top Preference)
    - #2-1: Steel-It, Stainless steel flake epoxy paint (epoxy more durable than latex)
    - #2-2: Powder coating
    - #2-3: FDA compliant paint
- **Food contact surfaces must be stainless steel**
- **Parts (1 year parts and necessary components):**
- **Lubricants need to be H1 compliant**
- **Electric:**
  - < ½ hp: 230 V, 50 Hz, Single Phase, provide appropriate electrical plug/plug adapter for Ghana and transformer if needed.
  - ≥ ½ hp: 400 V, 50 Hz, 3 Phase
- **Movement between processes:** Interconnecting equipment can be bid as an option in lieu of hand dumping.
- **Available floor space and ceiling height:**
  - Available floor space: 20 meters x 40 meters
  - Available ceiling height for equipment: ~5-8 meters
- **Fire Suppression:** If fire suppression is an available option for the white roaster and the roaster, quote as a separate option.
- **Utility requirements:** Vendor must specify the required utilities in quantity and characteristic (Ex. Total connected electric load, compressed air pressure and scfm).



### **Roasting Process Equipment Requirements:**

#### **Pre-cleaning:**

Purpose – remove heavy foreign material such as rocks, glass, steel parts, etc from shelled peanuts. Remove light foreign material such as stems, hulls, etc.

- Includes aspiration, scalping, gravity separator and destoner (See flow diagram in Annex II)
- Aspiration for removal of skins, fines, light foreign material, etc. Aspiration should include ductwork, cyclone, fan, fan discharge damper and collection bin. Dust collection can either be per unit of operation for pre-cleaning or a single system that each unit is tied into.
- For Scalping overs and unders: Easy change screening system on scalper for different market type peanuts (dual screens and frames, perforated slat size to be specified, slat size will be specified at time of order) Ex. Overs 1. X/64" x 3/4" slotted screen Overs 2. X/64" x 3/4" slotted screen. Unders 1. X/64" x 3/4" slotted screen Unders 2. X/64" x 3/4" slotted screen.
- Gravity Separator and Destoner: high quality scales/adjustment mechanism for varying size peanuts
- Ability to introduce peanuts via bags into cleaning process and discharge out of cleaning process into bins/storage container.
- Rare earth magnetic grate/plate installed with 100% product contact (located in an area with continuous uniform feed). Validated Pull Strength: Minimum 5 pounds, 1/4" carbon steel ball. Standard 2" gap is acceptable but will require deflector grids to ensure 100% contact with grates. Accessible and removable for adequate cleaning.
- Each pre-cleaning step needs metered flow and ability to move peanuts from machine to machine.
- Throughput: 473 kg/hr minimum (output)

#### **White Roaster (Raw):**

Purpose – heat peanuts to expand and cool nut to contract, this loosens skin prior to mechanical blanching.

- Enable 100% removal of skins in splitter/blancher.
- Reduce moisture in peanuts to 4-4.5%.
- Peanut temperature should not exceed 200°F.
- Peanuts should be cooled via ambient air to ambient temperature ( $\leq 90^{\circ}\text{F}$ ), see figure below for ambient temperature conditions in Kumasi, Ghana.

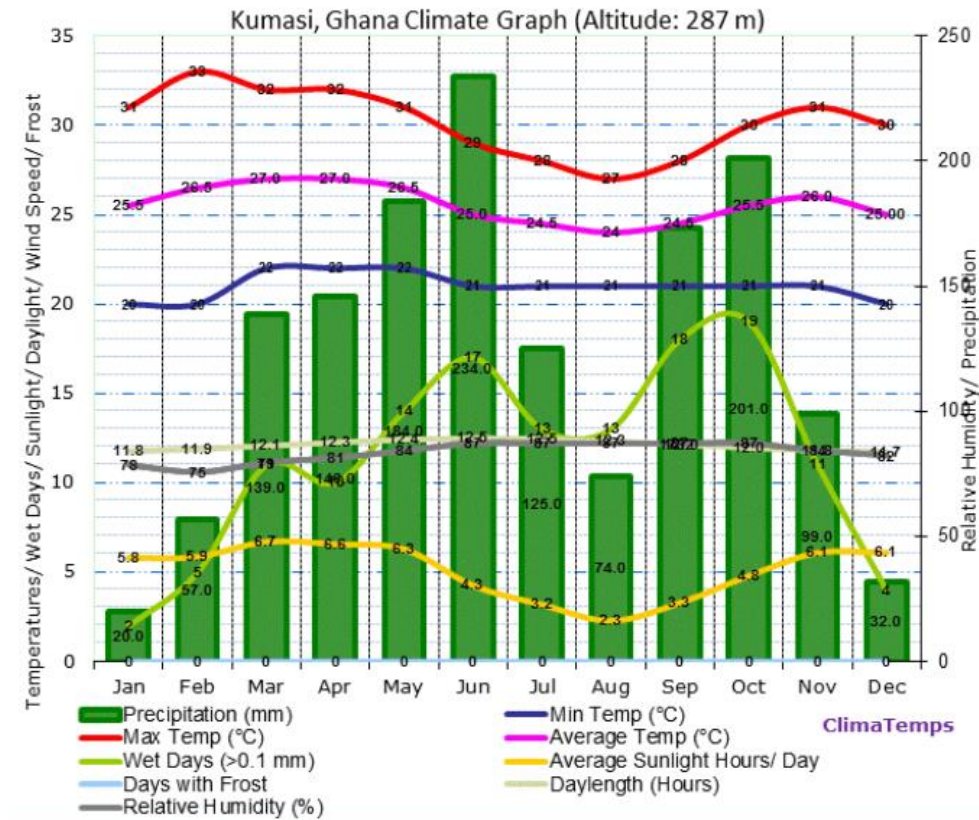

- Must be a separate system than the Roaster as the White Roaster system output is still considered raw.
- Ability to clean residual oil from food contact surfaces. Ability to use chemical agents for cleaning.
- Ability to introduce peanuts via bins/storage container into white roaster and discharge into bins/container.
- Air Inlet/Exhaust capabilities (Vendor needs to supply requirements)
- System must be electric, gas utility is not available.
- Throughput: 460 kg/hr minimum (output)

**Splitter/Mechanical Blancher:**

Purpose – split 100% of the peanut kernels, remove 100% of the skins. Screen out hearts, small pieces and meal. Prepare kernels for electronic sorting.

- Red nose kernels: 5% maximum
- Unblanched kernels: 1.5% maximum
- Broken and mechanically damaged kernels: 2.5% maximum
- Hearts, small pieces and meal: 0.5% maximum
- Ability to introduce peanuts via bins/storage container into blancher and discharge into bins/container.
- Aspiration for removal of skins. Aspiration should include ductwork, cyclone, fan, fan discharge damper and collection bin.
- Easy change screening system for removal of hearts, small pieces and meal (screen sizes to be specified at time of order) Ex. Screen #1: ¼" round, Screen #2: TBD)

- Throughput: 412 kg/hr minimum (output)

**Electronic Sorter:**

Purpose – Detect and remove damaged or discolored kernels, thereby reducing Aflatoxin levels.

- Capable of removing kernels with flesh discoloration (spots, pits and other), molded kernels, damage caused by insects.
- Full color high resolution RGB optical sorter
- Able to inspect both sides of each half of every split kernel.
- Accept and Reject stream
- Regulation of air pressure (supply TBD, probably max. 85 psi air pressure)
- Aspiration pickups (Vendor needs to supply size and cfm) or supply dedicated aspiration system.
- Easy access to both the feeding and sorting areas for maintenance and cleaning.
- Throughput: 360 kg/hr minimum (output)

**Manual Sorting:**

Purpose – Visual inspection of kernels as a supplement to Electronic sorting. Peanut kernels pass on a moving belt (mechanical or manual) in a monolayer and will be hand picked by employees.

Employees will be removing damaged kernels.

- Belt width max. of 200-250 mm per person visually inspecting the kernels, belt can be 400-500 mm in width if inspection can be completed from both sides of the belt.
- Belt material – food compliant, easy to clean, belt color will be specified.
- Variable speed
- Throughput: 360 kg/hr minimum (output)

**Roasting:**

Purpose – reduce moisture, roast to desired degree for flavor, color and stability, and achieve microbial reduction.

- Heated peanut temperature: Able to achieve range from 325-400°F
- Peanuts should be cooled via ambient air to ambient temperature ( $\leq 90^{\circ}\text{F}$ ), see graph in White Roaster section for ambient temperature conditions in Kumasi, Ghana.
- Achieve minimum 4 log reduction in Salmonella.
- Roasted peanut color: Hunter L value target: 46
- Peanut Moisture: Target 1.0%, Max. 1.5%
- Sensory: Flavor should be clean with fresh toasted nut flavor, free from rancid, stale, or off flavors. Odor should be clean, toasted nut odor, free from rancid or off odors.
- Must be a separate system than the Roaster as the white roaster system output is still considered raw.
- Ability to clean residual oil from food contact surfaces. Ability to use chemical agents for cleaning.
- Ability to introduce peanuts via bins/storage container into roaster and discharge into bins/container.
- System must be electric, gas utility is not available.
- System must be a dry roaster, oil roasting is not acceptable.
- Throughput: 350 kg/hr minimum (output)

**Peanut Handling/Transfer Equipment Requirements:**

Peanut handling equipment is required into, between, and out of the system. Because it is unknown how the vendors will design their components and systems we can only give general guidance on expectations and the vendor shall specify and quote best-simple technology to handle the peanuts.

**General Peanut Handling/Transfer Requirements:**

- All general requirements listed above apply.
- Conveyors, bins, etc. should be easy to clear and clean of peanuts and debris after production.
- Conveyors must be designed to properly feed the specific piece of equipment being conveyed too. For example if a process requires precise even feed, than an electrical/mechanical vibrating conveyor must be used.
- Bin sizes should be limited in size to what is minimally required.
- If processes can be integrated or stacked vertically above one another to take advantage of gravity from one process to another, this would be considered to eliminate the need for extra equipment or extra labor to handle peanuts between processes. An example of this could be in pre-cleaning where aspiration/scalping can be stacked above the Gravity separator, which can be stacked above the destoner if sufficient height exists.
- The equipment must be adequately guarded to prevent injury to personnel from moving equipment, pinch points, and sharp edges.
- Expectation is to minimize equipment requirements and costs.
- Hopper/surge bins can be integral to the subsequent equipment and therefore not needed within the conveying system. Vendor dependent based on equipment design.
- Product degradation must also be minimized throughout the process.

**Raw Peanut Feed:**

- It is assumed that the peanuts will arrive in 40+/- Kg bags.
- The initial material handling to the aspiration/scalper must be a bag dump system with an ergonomic dump height of 30 inches +/-.
- The dump station must have a sturdy grate that can support the bag weight and be removable to allow cleaning. The grate must also protect personnel from reaching into the moving conveyor.
- The conveying system must be designed to properly feed the cleaning equipment at the right rate and character. An adjustable speed conveyor either Variable Frequency or mechanical is likely needed. Vendor's system design will direct choice of variable speed.
- A rare earth magnet should be placed within the feed system to remove any tramp metal. The magnet must be easily accessible for inspection and cleaning at regular intervals of approximately 2 – 4 hours. Interruption of the process to access is acceptable.

**General Transfers between Processes**

- As required between processes, design and recommend the surge and transfer system between the remaining process excluding final roasted/cooled finished peanuts.
- At the transition between inspection and final roasting, there should be a method to allow us to introduce US supplied, cleaned, ready to roast peanuts into the roasting system without using the preceding equipment. This would be used until the location becomes 100% reliant on locally grown peanuts.

**Additional Peanut Process Equipment Requirements:**

**Controls:**

- Each unit of operation has own controls. As a separate option, may quote pre-cleaning as one control panel.

**Between Pre-Cleaning and White Roasting:**

- Assuming White Roasting is continuous, minimal surge hopper should be required. If vendor has ability to recommend size they should do so.
- Variable speed if required.

**Metal Detector:**

- Location of metal detector should be based on optimum performance/cost which may require location before or after the roaster.
  - Minimum Sensitivity: Ferrous - .8 mm, Non-ferrous – 1.0 mm, Stainless – 1.2 mm
- Integrated reject device, with light and horn for reject.

**Container for Finished Roasted Peanuts:**

After processing, finished roasted peanuts will be transferred from the cooler into containers. These containers will then be transported to the peanut butter making process in a separate room of the facility.

- Total quantity: 500, Each container should hold maximum of 23 kgs, minimum 18 kgs of roasted peanuts
- Composition: Sturdy food grade plastic with resealable lids, preference for twist and seal (lid can be one piece). Handle on each bucket. Able to be easily cleaned and reused.
- Container diameter: Maximum 14 inches
- Color to be specified, may include 2 color choices (Ex. White & Red).
- Example:



**Floor Scale:**

Roasted peanuts will be weighed into containers (above) per batch size requirements needed for the peanut butter making process.

- Weight capacity: 200 kg, 100 kg minimum,  $\pm 0.05$  kg resolution
- Size: Able to hold bucket/container (see above requirements)

**Pallet Trucks:**

Pallet trucks will be used to manually move pallets of raw and roasted peanuts around the facility.

- Quantity: 2
- Hand operated, hydraulic lift, manual push with standard configuration and tines
- Industrial, Heavy duty

- Weight requirements: Min. 5000 lbs

**Quality Assurance Laboratory Equipment Requirements:**

**Color meter (spectrophotometer)** – measure Hunter L value color on ground roasted peanuts.

- Color scale: Hunter L,a,b
- Illuminate/Observer: C/2
- Sample size ~300 grams
- Minimum 1” viewed area
- Sample dish capable of holding ~300 grams ground peanuts

**Moisture analyzer** – measure raw and roasted peanut moisture. Rapid loss-on-drying method with capabilities to adjust temperature and residence time. System must also have rapid cooling capabilities.

- Resolution of balance: 100 microgram balance.
- Moisture/Solids Range: 0.005 - 100%
- Moisture Resolution: 0.01% minimum
- Repeatability: 0.002% standard deviation (depends on test program)
- Balance Resolution: 0.001 g
- Temperature Range: 25°C to 275°C controlled to +/- 1°C
- Sample size: 100 mg to 40 g
- Test parameter memory: Ability to store up to 5 programs
- Results Display: Moisture, Solids, Dry Weight
- Linked Test Program: programmable temperatures for free and bound moisture
- Balance and heater calibration capabilities

**Vertical Cutter Mill** – homogeneous grinding of large sample of raw or roasted peanuts for Aflatoxin testing.

- Bowl capable of holding 8 kg – 16 kg peanut range
- Cutting insert (stainless steel), able to grind entire sample into homogeneous material
- Product contact surfaces must be stainless and easily cleanable.

[NEXT PAGE PEANUT ROASTING PROCESS]



**Cleaning  
 (RAW AREA)**

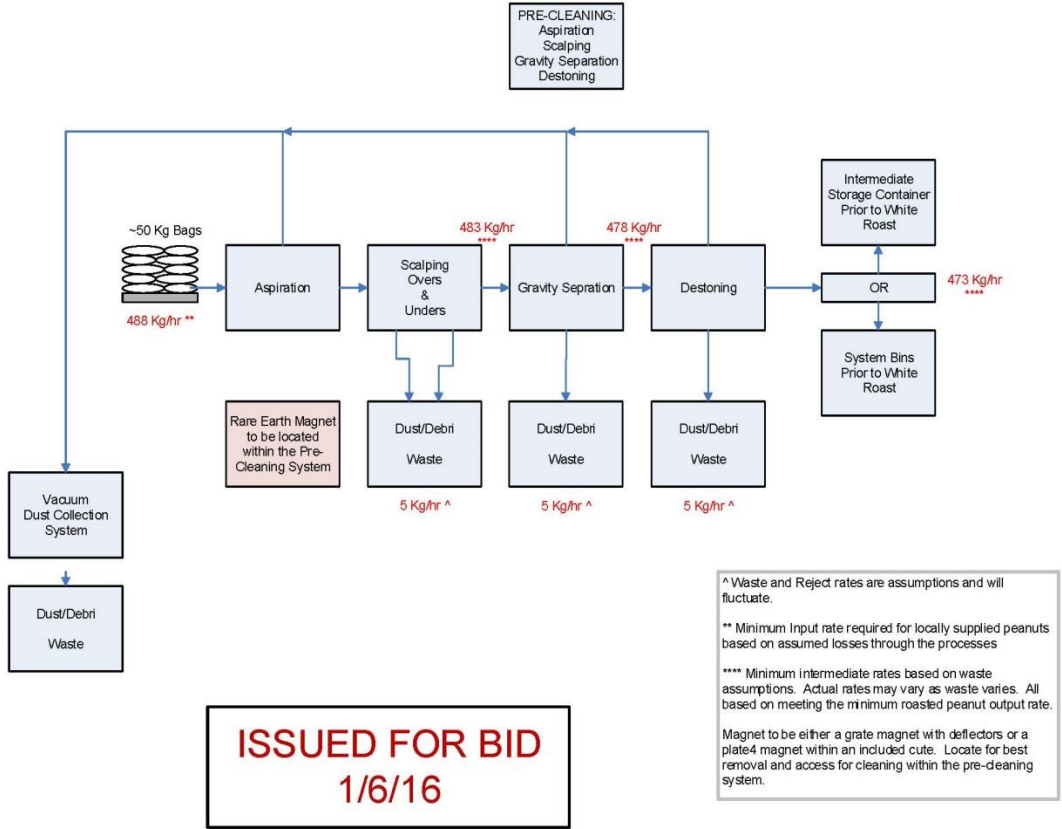



White Roasting, Blanching & Inspection  
 (Raw Area)

**ISSUED FOR BID**  
**1/6/16**

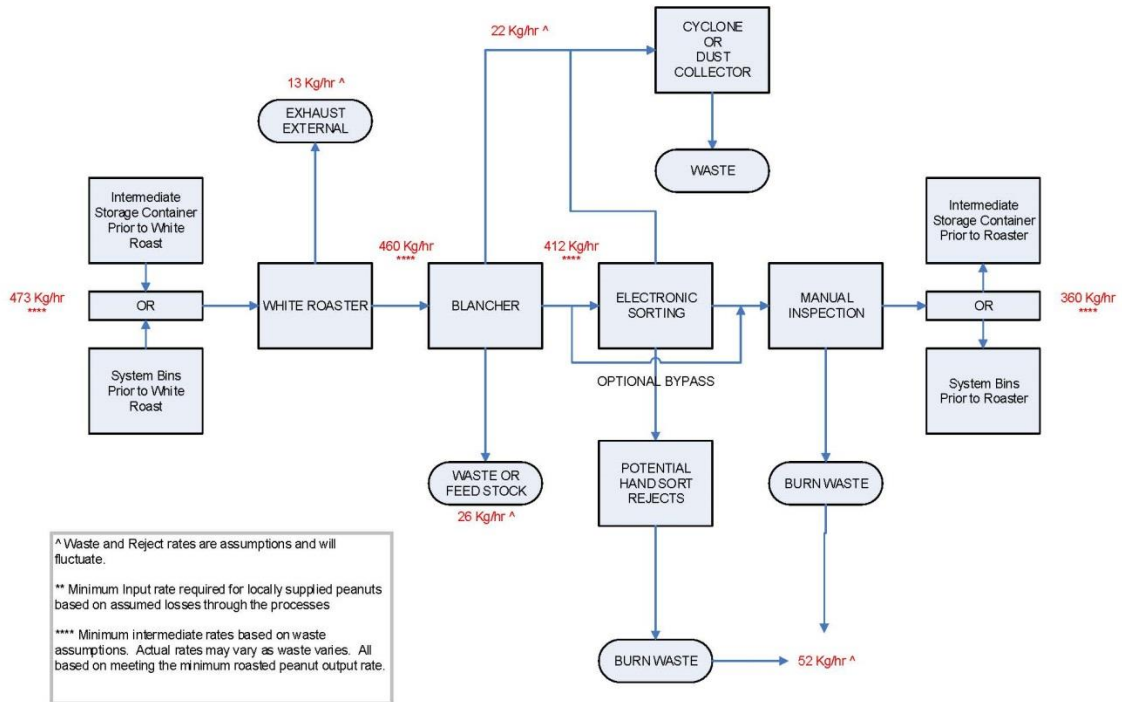

^ Waste and Reject rates are assumptions and will fluctuate.  
 \*\* Minimum Input rate required for locally supplied peanuts based on assumed losses through the processes  
 \*\*\*\* Minimum intermediate rates based on waste assumptions. Actual rates may vary as waste varies. All based on meeting the minimum roasted peanut output rate.

### FINAL ROASTING/COOLING

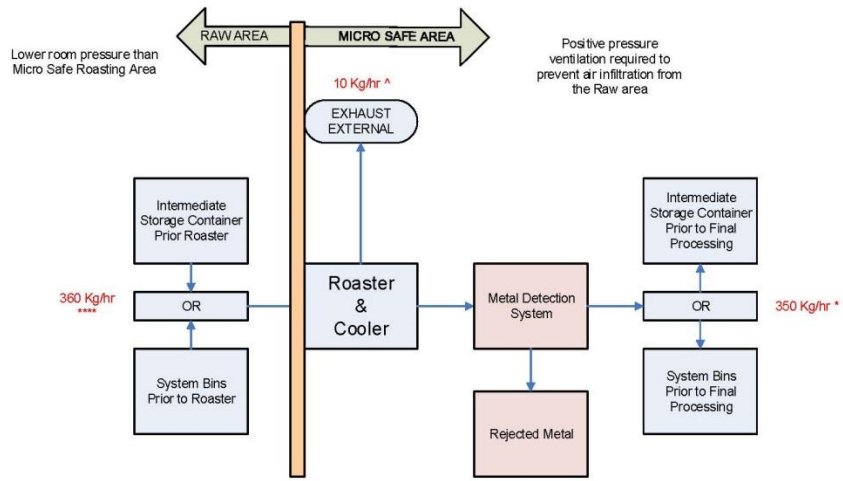

Waste and Reject rates are assumptions and will fluctuate.  
 \* Minimum Output Rate Required for finished roasted peanuts.  
 ^ Waste and Reject rates are assumptions and will fluctuate.  
 \*\*\*\* Minimum Intermediate rates based on waste assumptions. Actual rates may vary as waste varies. All based on meeting the minimum roasted peanut output rate.

**ISSUED FOR BID**  
**1/6/16**

## Annex 2: Equipment Specification Checklist

---

### Pre-cleaning: Aspiration & Scalping Overs & Unders

<b>Detailed Specifications – Vendor should comply with the minimum required specifications below where indicated.</b>	<b>Vendor to fill out</b>	
	<b>Provide Detailed Specifications for the Equipment Offered</b>	<b>Statement of Compliance Please Enter “Comply” or “Do Not Comply”</b>
Materials of construction: Food contact		
Materials of construction: Non-food contact		
Paint or coating specification (if required)		
Lubricants, H1 compliant		
Electric requirements (voltage, frequency, phase & amperage)		
Utility requirements (compressed air pressure & scfm)		
Throughput: Rated maximum output (kg/hr)		
Equipment overall dimensions (LxWxH)		
Easy change screening system with slat size options		
Metered product flow		
Notes/Comments		

## Pre-cleaning: Gravity Separation

	<b>Vendor to fill out</b>	
<b>Detailed Specifications – Vendor should comply with the minimum required specifications below where indicated.</b>	<b>Provide Detailed Specifications for the Equipment Offered</b>	<b>Statement of Compliance Please Enter “Comply” or “Do Not Comply”</b>
Materials of construction: Food contact		
Materials of construction: Non-food contact		
Paint or coating specification (if required)		
Lubricants, H1 compliant		
Electric requirements (voltage, frequency, phase & amperage)		
Utility requirements (compressed air pressure & scfm)		
Throughput: Rated maximum output (kg/hr)		
Equipment overall dimensions (LxWxH)		
High quality scales/adjustment mechanisms		
Metered product flow		
Is dust collection required and included?		
Notes/Comments		

## Pre-cleaning: Rare earth magnetic grate/plate

	<b>Vendor to fill out</b>	
<b>Detailed Specifications – Vendor should comply with the minimum required specifications below where indicated.</b>	<b>Provide Detailed Specifications for the Equipment Offered</b>	<b>Statement of Compliance Please Enter “Comply” or “Do Not Comply”</b>
Materials of construction: Food contact		
Throughput: Rated maximum output (kg/hr)		
Equipment overall dimensions (LxWxH)		
Confirmed 100% product contact with continuous uniform feed, provide gap and deflector grid configuration		
Validated Pull Strength		
Accessible and removable for adequate cleaning		
Notes/Comments		

## Pre-cleaning: Destoning

	<b>Vendor to fill out</b>	
<b>Detailed Specifications – Vendor should comply with the minimum required specifications below where indicated.</b>	<b>Provide Detailed Specifications for the Equipment Offered</b>	<b>Statement of Compliance Please Enter “Comply” or “Do Not Comply”</b>
Materials of construction: Food contact		
Materials of construction: Non-food contact		
Paint or coating specification (if required)		
Lubricants, H1 compliant		
Electric requirements (voltage, frequency, phase & amperage)		
Utility requirements (compressed air pressure & scfm)		
Throughput: Rated maximum output (kg/hr)		
Equipment overall dimensions (LxWxH)		
High quality scales/adjustment mechanisms		
Metered product flow		
Is dust collection required and included?		
Notes/Comments		

## White Roaster

	Vendor to fill out	
Detailed Specifications – Vendor should comply with the minimum required specifications below where indicated.	Provide Detailed Specifications for the Equipment Offered	Statement of Compliance Please Enter “Comply” or “Do Not Comply”
Materials of construction: Food contact		
Materials of construction: Non-food contact		
Paint or coating specification (if required)		
Lubricants, H1 compliant		
Electric requirements (voltage, frequency, phase & amperage)		
Utility requirements (compressed air pressure & scfm)		
Throughput: Rated maximum output (kg/hr)		
Equipment overall dimensions (LxWxH)		
Heat source (must be electric)		
Air inlet/exhaust capabilities		
Enable 100% removal of skins in splitter/blancher by skin loosening		
Moisture reduction in peanuts to 4.0-4.5%		
Temperature control to enable peanut temperature <200°F		
Peanut cooling to ambient (<90°F)		
Separate system than the Roaster (White Roaster output still considered raw).		
Wet cleaning capabilities with chemical agents		
Notes/Comments		

## Splitter/Mechanical Blancher

	<b>Vendor to fill out</b>	
<b>Detailed Specifications – Vendor should comply with the minimum required specifications below where indicated.</b>	<b>Provide Detailed Specifications for the Equipment Offered</b>	<b>Statement of Compliance Please Enter “Comply” or “Do Not Comply”</b>
Materials of construction: Food contact		
Materials of construction: Non-food contact		
Paint or coating specification (if required)		
Lubricants, H1 compliant		
Electric requirements (voltage, frequency, phase & amperage)		
Utility requirements (compressed air pressure & scfm)		
Throughput: Rated maximum output (kg/hr)		
Equipment overall dimensions (LxWxH)		
Air inlet/exhaust capabilities		
Red nose kernels: 5% max.		
Unblanched kernels: 1.5% max.		
Broken and mechanically damaged kernels: 2.5% max.		
Output hearts, small pieces and meal: 0.5% max.		
Split 100% of peanut kernels and remove 100% of peanut skins.		
Aspiration (ductwork, cyclone, fan, fan discharge damper and collection bin) for removal of skins.		
Easy change screening system for removal of hearts, small pieces and meal with 2 size options.		
Notes/Comments		



## Electronic Sorter

	<b>Vendor to fill out</b>	
<b>Detailed Specifications – Vendor should comply with the minimum required specifications below where indicated.</b>	<b>Provide Detailed Specifications for the Equipment Offered</b>	<b>Statement of Compliance Please Enter “Comply” or “Do Not Comply”</b>
Materials of construction: Food contact		
Materials of construction: Non-food contact		
Paint or coating specification (if required)		
Lubricants, H1 compliant		
Electric requirements (voltage, frequency, phase & amperage)		
Utility requirements (compressed air pressure & scfm)		
Throughput: Rated maximum output (kg/hr)		
Equipment overall dimensions (LxWxH)		
Capability to remove kernels with flesh discoloration (spots, pits and other), molded kernels, damage caused by insects.		
Full color high resolution RGB optical sorter		
Able to inspect both sides of each half of every split kernel		
Accept and Reject stream		
Easy access to both feeding and sorting areas for maintenance and cleaning.		
Aspiration pickups or supply dedicated aspiration system.		
Notes/Comments		

## Manual Sorting

	<b>Vendor to fill out</b>	
<b>Detailed Specifications – Vendor should comply with the minimum required specifications below where indicated.</b>	<b>Provide Detailed Specifications for the Equipment Offered</b>	<b>Statement of Compliance Please Enter “Comply” or “Do Not Comply”</b>
Materials of construction: Food contact		
Materials of construction: Non-food contact		
Paint or coating specification (if required)		
Lubricants, H1 compliant		
Electric requirements (voltage, frequency, phase & amperage)		
Utility requirements (compressed air pressure & scfm)		
Throughput: Rated maximum output (kg/hr)		
Equipment overall dimensions (LxWxH)		
Belt width max. 200-250 mm per person (can be 400-500 mm width if inspection on both sides of belt)		
Belt material – food compliant and easy to clean, belt color to be specified.		
Belt speed – variable, provide range in feet/minute		
Notes/Comments		

## Roaster

	Vendor to fill out	
Detailed Specifications – Vendor should comply with the minimum required specifications below where indicated.	Provide Detailed Specifications for the Equipment Offered	Statement of Compliance Please Enter “Comply” or “Do Not Comply”
Materials of construction: Food contact		
Materials of construction: Non-food contact		
Paint or coating specification (if required)		
Lubricants, H1 compliant		
Electric requirements (voltage, frequency, phase & amperage)		
Utility requirements (compressed air pressure & scfm)		
Throughput: Rated maximum output (kg/hr)		
Equipment overall dimensions (LxWxH)		
Heat source (must be electric)		
System must be a dry roaster, oil roasting is not acceptable		
Air inlet/exhaust capabilities		
Achieve minimum 4 log reduction in Salmonella		
Moisture reduction in peanuts to target 1.0%, 1.5% max.		
Temperature control to enable peanut temperature 325-400°F		
Roasted peanut color: Hunter L value target 46.0		
Peanut cooling to ambient ( $\leq 90^{\circ}\text{F}$ )		
Peanut Sensory: Flavor clean with fresh toasted nut flavor, free from rancid, stale or off flavors. Odor should be clean, toasted nut odor, free from rancid or off odors.		
Separate system than the White Roaster (White Roaster output still considered raw).		
Wet cleaning capabilities with chemical agents		
Notes/Comments		

## Peanut Handling/Transfer Equipment Requirements \*

	Vendor to fill out	
	Provide Detailed Specifications for the Equipment Offered	Statement of Compliance Please Enter "Comply" or "Do Not Comply"
<b>Detailed Specifications – Vendor should comply with the minimum required specifications below where indicated.</b>		
Type of Conveyor (Incline Belt, Bucket Elevator, vibrating, etc)		
Materials of construction: Food contact		
Materials of construction: Non-food contact		
Paint or coating specification (if required)		
Lubricants, H1 compliant		
Electric requirements (voltage, frequency, phase & amperage)		
Utility requirements (compressed air pressure & scfm)		
Throughput: Rated maximum output (kg/hr)		
Equipment overall dimensions (LxWxH)		
Belt or Bucket Speed (feet/min or buckets/min)		
Vibration type if applicable (Electromechanical, Eccentric Motors, counter-balanced, etc)		
Method of feed rate control (Manual, VFD, Vibration Control, etc.)		
Notes/Comments		

\* Use form for each conveyor or transfer system

## Metal Detector

	<b>Vendor to fill out</b>	
<b>Detailed Specifications – Vendor should comply with the minimum required specifications below where indicated.</b>	<b>Provide Detailed Specifications for the Equipment Offered</b>	<b>Statement of Compliance Please Enter “Comply” or “Do Not Comply”</b>
Materials of construction: Food contact		
Materials of construction: Non-food contact		
Paint or coating specification (if required)		
Lubricants, H1 compliant		
Electric requirements (voltage, frequency, phase & amperage)		
Throughput: Rated maximum output (kg/hr)		
Equipment overall dimensions (LxWxH)		
Minimum sensitivity requirements achieved: Ferrous – 0.8 mm Non-ferrous – 1.0 mm Stainless – 1.2 mm		
Integrated reject device with light and horn for reject		
Notes/Comments		

## Container for Finished Roasted Peanuts

	<b>Vendor to fill out</b>	
<b>Detailed Specifications – Vendor should comply with the minimum required specifications below where indicated.</b>	<b>Provide Detailed Specifications for the Equipment Offered</b>	<b>Statement of Compliance Please Enter “Comply” or “Do Not Comply”</b>
Materials of construction: Food contact		
Materials of construction: Non-food contact		
Quantity		
Weight Capacity (Consider density of roasted peanuts)		
Container dimensions (LxWxH)		
Resealable lid (preference for twist and seal)		
Cleanable and reusable?		
Color options		
Notes/Comments		

## Floor Scale

	<b>Vendor to fill out</b>	
<b>Detailed Specifications – Vendor should comply with the minimum required specifications below where indicated.</b>	<b>Provide Detailed Specifications for the Equipment Offered</b>	<b>Statement of Compliance Please Enter “Comply” or “Do Not Comply”</b>
Materials of construction:		
Paint or coating specification (if required)		
Electric requirements (voltage, frequency, phase & amperage)		
Weight Capacity (100 kg minimum, prefer 200 kg with ± 0.05 kg resolution)		
Scale dimensions (LxWxH), needs to be able to hold bucket/container		
Notes/Comments		

**Pallet Trucks:**

	<b>Vendor to fill out</b>	
<b>Detailed Specifications – Vendor should comply with the minimum required specifications below where indicated.</b>	<b>Provide Detailed Specifications for the Equipment Offered</b>	<b>Statement of Compliance Please Enter “Comply” or “Do Not Comply”</b>
Quantity (2 required)		
Materials of construction:		
Paint or coating specification (if required)		
Weight Capacity (Min. 5000 lbs)		
Hand operated, hydraulic lift, manual push with standard configuration and tines		
Industrial, heavy duty		
Notes/Comments		



Color meter (spectrophotometer):

	<b>Vendor to fill out</b>	
<b>Detailed Specifications – Vendor should comply with the minimum required specifications below where indicated.</b>	<b>Provide Detailed Specifications for the Equipment Offered</b>	<b>Statement of Compliance Please Enter “Comply” or “Do Not Comply”</b>
Sample size (~300 g required)		
Viewing area: 1” minimum		
Sample dish capable of holding ~300 g roasted peanuts		
Color Scale: Hunter L, a, b		
Illuminate/observer: C/2		
Electric requirements (voltage, frequency, phase & amperage)		
Notes/Comments		

## Moisture Analyzer:

	<b>Vendor to fill out</b>	
<b>Detailed Specifications – Vendor should comply with the minimum required specifications below where indicated.</b>	<b>Provide Detailed Specifications for the Equipment Offered</b>	<b>Statement of Compliance Please Enter “Comply” or “Do Not Comply”</b>
Resolution of Balance (100 micrograms)		
Moisture/Solids Range: 0.005-100%		
Moisture Resolution: 0.01% minimum		
Repeatability: 0.002% standard deviation (depends on test program)		
Balance Resolution: 0.001 g		
Temperature Range: 25°C to 275°C controlled to ± 1°C		
Sample size: 100 mg to 40 g		
Test parameter memory: Ability to store up to 5 programs		
Results Display: Moisture, Solids, Dry Weight		
Linked Test Program: programmable temperatures for free and bound moisture		
Balance and heater calibration capabilities		
Electric requirements (voltage, frequency, phase & amperage)		
Notes/Comments		

## Vertical Cutter Mill:

	<b>Vendor to fill out</b>	
<b>Detailed Specifications – Vendor should comply with the minimum required specifications below where indicated.</b>	<b>Provide Detailed Specifications for the Equipment Offered</b>	<b>Statement of Compliance Please Enter “Comply” or “Do Not Comply”</b>
Materials of construction: Food contact surfaces must be stainless steel and easily cleanable.		
Materials of construction: Non-food contact		
Paint or coating specification (if required)		
Bowl capacity (8-16 kg peanuts)		
Cutting insert (stainless steel), able to grind entire sample into homogenous material		
Notes/Comments		

### Annex 3: Past Performance Information Table

Item #	Project Name or Contract	Brief Description of Scope of Work and Activities	Geographic Location (country, region, district)	Period of Performance	Total Project Budget or Contract Value (USD\$)	Contact Details of Funder or Company (Name, Address, Email)
1						
2						
3						
4						
5						

**INSTRUCTIONS**

Complete the above past performance table based on other projects, contracts, or awards for similar work as described in the RFP, Annex 1, Terms of Reference. Preferably at least three (3) entries. Add more lines, if applicable.

## Annex 4: Certifications

---

### **CERTIFICATION REGARDING TERRORIST FINANCING**

Within the following certification the term "JSI" shall be substituted for the term "USAID". "Proposal shall be substituted for the term "application".

#### **CERTIFICATION:**

By signing and submitting this application, the prospective recipient provides the certification set out below:

1. The Recipient, to the best of its current knowledge, did not provide, within the previous ten years, and will take all reasonable steps to ensure that it does not and will not knowingly provide, material support or resources to any individual or entity that commits, attempts to commit, advocates, facilitates, or participates in terrorist acts, or has committed, attempted to commit, facilitated, or participated in terrorist acts, as that term is defined in paragraph 3.

2. The following steps may enable the Recipient to comply with its obligations under paragraph 1:

a. Before providing any material support or resources to an individual or entity, the Recipient will verify that the individual or entity does not (i) appear on the master list of Specially Designated Nationals and Blocked Persons, which is maintained by the U.S. Treasury's Office of Foreign Assets Control (OFAC), or (ii) is not included in any supplementary information concerning prohibited individuals or entities that may be provided by USAID to the Recipient.

b. Before providing any material support or resources to an individual or entity, the Recipient also will verify that the individual or entity has not been designated by the United Nations Security (UNSC) sanctions committee established under UNSC Resolution 1267 (1999) (the "1267 Committee") [individuals and entities linked to the Taliban, Usama bin Laden, or the Al-Qaida Organization]. To determine whether there has been a published designation of an individual or entity by the 1267 Committee, the Recipient should refer to the consolidated list available online at the Committee's Web site: <http://www.un.org/Docs/sc/committees/1267/1267ListEng.htm>.

c. Before providing any material support or resources to an individual or entity, the Recipient will consider all information about that individual or entity of which it is aware and all public information that is reasonably available to it or of which it should be aware.

d. The Recipient also will implement reasonable monitoring and oversight procedures to safeguard against assistance being diverted to support terrorist activity.

3. For purposes of this Certification –

a. "Material support and resources" means currency or monetary instruments or financial securities, financial services, lodging, training, expert advice or assistance, safehouses, false documentation or

identification, communications equipment, facilities, weapons, lethal substances, explosives, personnel, transportation, and other physical assets, except medicine or religious materials.”

b. “Terrorist act” means –

- (i) an act prohibited pursuant to one of the 12 United Nations Conventions and Protocols related to terrorism (see UN terrorism conventions Internet site: <http://untreaty.un.org/English/Terrorism.asp>); or
- (ii) an act of premeditated, politically motivated violence perpetrated against noncombatant targets by subnational groups or clandestine agents; or
- (iii) any other act intended to cause death or serious bodily injury to a civilian, or to any other person not taking an active part in hostilities in a situation of armed conflict, when the purpose of such act, by its nature or context, is to intimidate a population, or to compel a government or an international organization to do or to abstain from doing any act.

c. “Entity” means a partnership, association, corporation, or other organization, group or subgroup.

d. References in this Certification to the provision of material support and resources must not be deemed to include the furnishing of USAID funds or USAID-financed commodities to the ultimate beneficiaries of USAID assistance, such as recipients of food, medical care, micro-enterprise loans, shelter, etc., unless the Recipient has reason to believe that one or more of these beneficiaries commits, attempts to commit, advocates, facilitates, or participates in terrorist acts, or has committed, attempted to commit, facilitated or participated in terrorist acts.

e. The Recipient’s obligations under paragraph 1 are not applicable to the procurement of goods and/or services by the Recipient that are acquired in the ordinary course of business through contract or purchase, e.g., utilities, rents, office supplies, gasoline, etc., unless the Recipient has reason to believe that a offeror or supplier of such goods and services commits, attempts to commit, advocates, facilitates, or participates in terrorist acts, or has committed, attempted to commit, facilitated or participated in terrorist acts. This Certification is an express term and condition of any agreement issued as a result of this application, and any violation of it will be grounds for unilateral termination of the agreement by USAID prior to the end of its term.

OFFEROR:

\_\_\_\_\_

Authorized Signatory:

\_\_\_\_\_

Title:

\_\_\_\_\_

Date:

\_\_\_\_\_

**CERTIFICATION REGARDING DEBARMENT, SUSPENSION, OR PROPOSED  
DEBARMENT**

By signing and submitting this certification, the prospective recipient provides the certification set out below:

By signing and submitting this certification, the prospective recipient provides the following assertion: to the best of its knowledge and belief, the prospective recipient and/or any of its Principals are ( ) are not ( ) presently debarred, suspended, proposed for debarment, or declared ineligible for award of contracts by any Federal agency.

OFFEROR: \_\_\_\_\_

Authorized Signatory: \_\_\_\_\_

Title: \_\_\_\_\_

Date: \_\_\_\_\_

## ANNEX 5: STANDARD GENERAL CONTRACT TERMS AND CONDITIONS for USAID-FINANCED, INTERNATIONAL SUPPLY OF GOODS (COMMERCIAL ITEMS)

---

**[Note: See Article 33 for Definitions of Terms]**

### 1. THE CONTRACT

- A. The Contract consists of the Order Form, these Standard General Terms and Conditions ("SGTCs), and the following Special Contract Terms and Conditions (SCTC's), if checked:

- Pharmaceutical Products (Appendix A)
- Quality Assurance Testing and Inspection (Appendix B)
- Provision of Services (Appendix C)
- Liquidated Damages for Delay (Appendix D)
- President's Malaria Initiative (Appendix E)
- Medical Equipment (Appendix F)
- Additional clauses (Appendix G)

- B. In the event of conflict or inconsistency, the terms of the Order Form shall prevail over the SCTCs and the SGTCs, and the SCTCs shall prevail over the SGTCs.

### 2. GOODS AND RELATED SERVICES

- A. Vendor agrees to sell the Goods (and perform the Related Services, if any) described on the Order Form, in accordance with the terms stated thereon.
- B. The quality of the Goods and Services shall conform in all respects to the requirements of the Contract (including, but not limited to, all required warranties).
- C. All Goods (including, but not limited to, materials, parts, components, and sub-assemblies thereof) shall, unless otherwise expressly approved by Buyer in writing, be new, and not used, remanufactured, refurbished or previously disposed as Government surplus; and shall be produced entirely from goods meeting all of the foregoing requirements.
- D. Unless otherwise expressly approved by Buyer in writing (based on approval by the Government's Agreement Officer)—
- [1] the origin of any of the Goods for which a specific "Origin" is indicated on the Order Form shall be as specified; and
  - [2] the Goods (including the components thereof), services, sub-vendors or subcontractors shall not be from Cuba, Iran, Laos, Libya, Sudan, Syria, or North Korea. For most up to date list, see: <http://www.usaid.gov/ads/policy/300/310>
- E. Notwithstanding any other provision of the Contract, Buyer may do either or both of the following:



- [1] prior to shipment of the Goods and the initiation of performance of any Related Services, by written notice to Vendor, cancel in its entirety, or reduce the quantity(ies) of, any individual item(s) of the Goods without charge to Buyer; or
- [2] in the event that the USAID Agreement is terminated by the Government in whole or in pertinent part prior to shipment, return to Vendor unused items or quantities of Delivered Goods.

### **3. PACKING, EXPORT MARKING, PREPARATION FOR SHIPMENT AND PACKAGING**

Vendor shall pack and mark the Goods for export as required by the Contract, and by all applicable transportation regulations, carrier tariffs, USFDA/SRA regulations (if any), and sound commercial practice. Without limiting the generality of the foregoing--

- A. All Goods shall be properly prepared for export to withstand exposure to the elements and rough handling during air, sea or land shipment.
- B. Packing must be sufficient to ensure safe arrival at destination, and must fully cover such hazards as extreme temperature, exposure to weather, and open storage. Where appropriate, packing size and weights shall take into consideration the remoteness of the Goods' destination and the absence of heavy handling facilities at some or all points during transit.
- C. Vendor shall be solely responsible for complying with all Cooperating Country laws and sound international practices for the packaging and labeling of the Goods (including, if applicable, hazardous materials safeguards).
- D. Unless otherwise provided on the Order Form, Vendor shall mark each unit of export packaging with the JSI Contract number specified on the Order Form, and shall enclose a packing slip with that number in a secure and durable envelope.
- E. Damage resulting from improper packing, export marking and preparation for shipment shall be for Vendor's account.
- F. No extra charge shall be payable by Buyer for export packaging, crating, boxing, handling, dunnage, drayage, storage, or any other action necessary to comply with the requirements of this clause unless specifically stated in the Contract or otherwise agreed to by Buyer in writing.

### **4. EXPORT AND TRANSPORTATION CLEARANCES**

Vendor's responsibilities in connection with export and transportation clearances depend on the applicable delivery term, as modified by the terms of the Contract.

### **5. GOODS AVAILABILITY AND DELIVERY**

- A. Delivery of the Goods shall be affected on the basis of the Incoterm specified on the Order Form, as such term is defined in Publication No. 620 of the International Chamber of Commerce (Incoterms

2000), as modified by the specific delivery requirements set forth in the Contract. In the event of any conflict or inconsistency between a specific delivery requirement and the relevant Incoterm, the specific delivery requirement shall prevail.

- B. Vendor shall make the Goods available for sampling, testing, inspection and/or delivery on or before the Goods Available Date specified on the Order Form.
- C. Unless explicitly authorized on the Order Form or otherwise approved by Buyer in writing (under such conditions as Buyer may impose), all items and quantities of the Goods shall be made available at the same time; tender of a portion of the Goods shall not be acceptable. In the event of short/partial tender, in addition to any other rights specified in the Contract, or available in law or in equity, Buyer may, at its sole discretion, either
  - [1] reject the Goods in their entirety, in which case Vendor shall promptly pay Buyer upon demand any excess costs of re-procurement;
  - [2] deem any quantity of Goods not yet tendered to be rejected, and reduce the Total Contract Price accordingly; or
  - [3] authorize Vendor to make up the shortage at a later date.
- D. If Vendor tenders any item of the Goods in excess of the quantity called for in the Order Form, such excess quantity shall be treated as being tendered for the convenience of Vendor. Buyer may retain such excess quantity without compensating Vendor therefore, and Vendor waives all right, title, or interest therein.
- E. Vendor shall notify Buyer when the Goods are available by sending a Notice of Availability by e-mail to the JSI Contact identified on the Order Form. The notice shall clearly reference the JSI Contract Number, and shall include:
  - [1] a Commercial Invoice;
  - [2] a Packing List with weights and dimensions;
  - [3] if the Goods include pharmaceuticals, a Certificate of Analyses;
  - [4] where the delivery term is EXW or FCA, the name of the Vendor representative responsible for collecting the Goods and transferring them to Buyer's nominated carrier, and
  - [5] such other information and documents as are specified in the Contract (such as a Certificate of Origin or a Certificate of Pharmaceutical Product), and as Buyer may reasonably request from time to time.
- F. Upon receipt of a Notice of Availability—

- [1] Where the Contract delivery term is EXW or FCA, within three working days after receipt, Buyer shall endeavor to arrange for the Goods to be collected or give instructions to Vendor for transfer of the Goods to the nominated carrier.
  - [2] For all other Contract delivery terms, within a reasonable time after receipt, Buyer shall issue an Authorization to Deliver; provided, that if the Contract calls for pre-shipment quality assurance testing, Buyer shall promptly arrange for such testing, and shall issue an Authorization to Deliver promptly upon receipt of the results thereof for all Goods that pass.
- G. Upon receipt of an Authorization to Deliver, Vendor shall immediately proceed to complete delivery of the Goods in accordance with the Contract delivery term.
- H. Where Vendor is required to arrange shipment, shipments by sea shall be on an FCL/FCL (Full Container Load) basis, and via an American flag carrier, to the extent required by Cargo Preference regulations. Prior to such shipment, or immediately upon availability, Vendor shall send the following original documents by express courier, and PDF copies of those documents by e-mail, to the JSI Contact identified on the Order Form:
- [1] Rated Air Waybill, or ocean Bill of Lading;
  - [2] Insurance Certificate (if required by the Contract delivery term);
  - [3] Packing List;
  - [4] Commercial Invoice;
  - [5] any other document included with the Notice of Availability; and
  - [6] such other documents as Buyer may reasonably request from time to time.
- The Air Waybill (for air shipment) or the Bill of Lading (for ocean shipment) shall be clean, on-board, marked "freight paid" issued by the vessel-owning common carrier, and on a through basis (covering all intermodal and/or inland transportation, if any, to destination). The Certificate of Insurance shall provide all risk marine cargo insurance on terms no less favorable than the Institute Cargo Clause (All Risks), including war risks and strike clauses. The amount of coverage shall be 110% of the delivered price of the Goods, and shall be from Vendor's facility in the country of manufacture to the final destination. Except as otherwise authorized by Buyer, the policy shall name JSI as the insured, and any loss proceeds shall be payable in United States Dollars.
- I. Vendor shall advise Buyer of all information concerning the Goods that is pertinent to the transportation and in-country handling and storage (including, but not limited to, any hazardous material indications and any other special handling and storage requirements), and shall be solely responsible for the consequences of any failure to do so.
- J. Buyer shall secure any necessary licenses, approvals, permits, and other authorizations, and effectuate the required customs clearance, needed for the importation of the Goods into the country of destination. Vendor shall provide all reasonable assistance toward performance of

Buyer's responsibilities. For other than EXW deliveries, Vendor shall also be solely responsible for all costs and risks relating to payment of all duties, taxes, and other official charges assessed on exportation from the country of manufacture and shipment. Any import duties or other exactions assessed by the government of the country of destination, as well as container demurrage/detention and comparable charges shall be for the Buyer's account, except for [a] container demurrage/detention and comparable charges levied in those instances in which Vendor fails to comply with the shipping document delivery schedule as specified in Paragraph H above or has otherwise caused the delays giving rise to such demurrage/detention or comparable charges; and [b] the costs of duties, taxes, and similar official import charges on replacement Goods, when required due to the Goods originally supplied by Vendor having been defective.

## **6. PRICE**

- A. The Prices (Unit Prices and extended prices) specified in the Order Form are firm, fixed, all-inclusive total prices covering performance of all of Vendor's obligations under the Contract, including, but not limited to, delivery of the Goods in accordance with the Contract delivery term and performance of all Associated and Related Services; warranty-related costs and charges; packing, packaging and marking costs; the costs of cooperating with sampling, testing, inspection and other quality assurance requirements, when applicable; and any and all other costs and charges of whatever description or amount in connection with, necessary for, or resulting from Vendor's required performance.
- B. Vendor certifies that the Price(s) in the Contract represent the lowest price(s) at which Vendor currently sells the Goods under comparable terms and conditions to any of its customers. If during the life of the Contract Vendor sells the Goods to any customer for a lower price, it will promptly inform Buyer and execute an Amendment to the Contract so that such lower price applies to any pending or subsequent Goods delivered hereunder.
- C. The Total Contract Price specified on the Order Form shall constitute the maximum ceiling for Buyer's liability to Vendor for any and all reasons whatsoever in connection with or resulting from the Contract.

## **7. INVOICING AND PAYMENT**

- A. Invoices and payments shall be in United States Dollars, unless otherwise stated in the Order Form. Invoices shall be sent to and paid by:

John Snow, Inc. (JSI)  
Attn. USAID | SPRING PROJECT  
1616 N. Ft. Myer Drive, 16th Floor  
Arlington, Virginia, 22209  
USA

- B. To constitute a "proper invoice" within the meaning of this Article 7, the invoice shall provide the following information supported by such other documents as are specified in the Order Form:

- [1] Vendor name, invoice date, and delivery date (for Goods) or performance date (for Related Services), as applicable;
- [2] Complete account and bank's SWIFT information if payment by means of electronic funds transfer is preferred;
- [3] JSI Agreement number and, if applicable, Order Form number;
- [4] Description of each type of Goods and Related Services included in the invoice, together with the applicable Contract Unit Price, quantity delivered, and extended line item price;
- [5] The Vendor Certification, set forth below, manually signed by an authorized official of Vendor; and
- [6] Such other documentation as may be requested by Buyer in relation to the Goods and/or Related Services.

#### **VENDOR CERTIFICATION**

The undersigned hereby certifies that (i) the invoice has been prepared from Vendor's books and records in accordance with the terms of the cited Contract, and to the best of my knowledge and belief, it is correct, the sum claimed is proper and due and has not been claimed or paid before, the Goods have been delivered and all required Services have been performed, the quantities and prices specified are consistent with the Contract, and all necessary Buyer approvals have been obtained, and (ii) appropriate refund to Buyer will be made promptly upon request in the event of disallowance of any portion of the invoice pursuant to the terms of the Contract by Buyer or the Government.

By: \_\_\_\_\_

Title: \_\_\_\_\_

Date: \_\_\_\_\_

- C. Buyer will promptly review invoices submitted to determine whether they are proper invoices. Invoices determined to be proper will be paid by Buyer within thirty (30) days of receipt, subject always to Buyer's prior receipt of funds designated for such payment under the USAID Agreement. Invoices determined not to be proper will be returned to Vendor, generally within ten (10) business days of submission, with deficiencies noted for correction. In the event that an invoice is submitted which is partly proper and partly not proper, Buyer may, at its sole discretion, either return the entire invoice for correction or make payment of the proper portion and return the portion deemed not to be proper. Notwithstanding the foregoing, Buyer accepts no responsibility for any late payment resulting from Government acts or omissions.

- D. Unless otherwise stated in the Order Form, Buyer shall pay Vendor 100% of the Total Contract Price upon delivery. Buyer may request reasonable security for any advance payment(s), in a form and substance acceptable to Buyer and the Government, and with all costs thereof to be for Vendor's account.
- E. If payment(s) will be made electronically, Vendor shall be solely responsible for providing Buyer with correct wiring information. All costs and risks arising out of, relating to, or resulting from such wiring shall be borne by Vendor.

**8. TITLE AND RISK OF LOSS OR DAMAGE**

- A. Title to the Goods shall pass, in accordance with applicable law, directly to JSI Research & Training Institute, Inc., or unless otherwise stated.
- B. Risk of loss or damage to the Goods shall be borne by Vendor and Buyer, respectively, in accordance with the requirements of the Contract delivery term, except that each Party shall be responsible for any loss or damage if, and to the extent that, such loss or damage is due to that Party's negligent, willful or intentional conduct.

**9. VENDOR WARRANTIES**

- A. All Goods delivered and Services rendered hereunder shall be covered by the Manufacturer's standard international warranty in favor of JSI Research & Training Institute, Inc.
- B. In addition and without prejudice to Paragraph A above, Vendor warrants that the Goods and Services delivered and rendered hereunder are merchantable and fit for use for the particular purpose described in the Contract (or, if no such purpose is specifically described, for the purposes for which the Goods or Services, as applicable, are ordinarily used).
- C. Vendor also hereby expressly warrants that all Goods (including without limitation their parts) and Services supplied, as applicable:
  - [1] conform to Contract requirements (including without limitation the description in the Contract and the Specifications), as well as, if one or more specific Cooperating Countries is mentioned in the solicitation or the Contract, the requirements of that Cooperating Country and any other applicable regulatory agencies' requirements, and are free of defects in design;
  - [2] are free of latent defects (as used herein, defects that meet the following criteria: (a) such defects are not apparent to either Party during customary manufacturing or quality testing and/or inspection; and (b) such defects result solely from defective material, workmanship, or design and are not caused by misuse or misapplication of the Goods);
  - [3] will, to the extent found to be in breach of any warranty specified in the Contract, be removed, and repaired or replaced, covered by new warranties identical to those that applied to the originally supplied Goods and Services, extending for the longer of [a] the remainder of the original warranty period, or [b] a new warranty period;

- [4] ensure that all spares and replacement parts are the same as the original spares and parts unless formally replaced by an improved and Buyer-approved technical equivalent; and
- [5] are covered by intellectual property licenses, patents, permissions, or rights which will not infringe the intellectual property rights of any third person, and which, being granted to Buyer and the Government pursuant to the Contract, will be adequate to ensure that they may freely utilize the licenses, permissions and rights free and clear of any claim, encumbrance, lien or interest of any other person or entity, and in all other respects without disturbance or impediment.
- D. The period of all warranties set forth in this Article or in any other provision of the Contract shall be as stipulated on the Order Form.
- E. If any Goods or Services supplied hereunder are defective or otherwise do not meet the warranties specified herein or otherwise applicable at any time during the warranty period, Buyer may, at its option: (1) reject the affected item(s) and require a full refund or credit; (2) reject the affected item(s) and require prompt correction or replacement (freight prepaid) at Vendor's sole expense; (3) retain it/them at an equitably adjusted price; or (4) require Vendor to provide, if available, corrections in the form of field change order kits (including components, instructions and other necessary materials) from Vendor so that Buyer or its designee may make necessary changes or repairs. Repaired or corrected items shall be subject to the same warranties as if they were new. While returned item(s) are in Vendor's possession and while in transit during return to Vendor and reshipment to or as directed by Buyer, all risks and costs of loss, destruction or damage shall be for Vendor's account.
- F. Buyer shall submit warranty claims to Vendor within a reasonable time after discovery of any breach, indicating the nature and date of the claim.
- G. Vendor shall promptly correct any problem reported by the Government and/or Buyer by making necessary changes in the Goods or their manufacturing processes so that further Goods to be delivered to the Government and/or Buyer shall be as warranted herein. If Vendor becomes aware of any non-conformance to any warranty relating to the Delivered Goods, Vendor shall promptly notify Buyer thereof in writing.
- H. Buyer shall have the right, at any time and from time to time, to stop further deliveries of Goods from Vendor that do not conform to the warranties and other requirements of the Contract, and in such event Buyer shall advise Vendor of Buyer's best identification and assessment of the problems. Further deliveries of Goods shall not be made to Buyer until and unless Vendor has corrected the specified areas of non-conformance in the Goods, or Buyer authorizes in writing the shipment of such Goods pending Vendor's correction. Buyer's actions pursuant to this Paragraph shall not be deemed to constitute a change order, and Vendor shall not be entitled to any compensation due to the delays (if any) associated with or resulting from these actions.

## **10. SERVICE BULLETINS, RECALLS, AND COUNTERFEITING NOTICES**

- A. Vendor shall promptly provide the Buyer with any service bulletins, safety notices and recall notices etc. issued by Vendor (or, if Vendor is not the manufacturer, by the Manufacturer) either directly or via the Manufacturer's local agent, if any.
- B. Vendor shall promptly provide the Buyer with written notice (including all pertinent particulars) regarding instances that may come to its attention by whatever means of possible counterfeiting, piracy, or unauthorized sales by third parties of diluted, adulterated, impure, misbranded, mislabeled, unsafe, ineffective, inefficacious, or otherwise non-standard items of the same type and brand as the Goods supplied in the Cooperating Countries.
- C. Notwithstanding any other provision in the Contract or any other agreement between the Parties, Buyer may disclose this information to appropriate authorities of the U.S. Government or the Cooperating Country governments, as well as others, as deemed necessary in Buyer's sole discretion to perform the USAID Contract, comply with its obligations under applicable law, or otherwise. The obligations under this Article shall continue to apply until the end of the warranty period of all Goods furnished by Vendor pursuant to the Contract.

Vendor will provide Buyer or its Quality Assurance designee access, upon request, to information, and any documentation related to product quality complaints, investigations conducted by the manufacturer, or any medical adverse event reports, and/or trends that are directly related to the supplied product.

## **11. CHANGE ORDERS**

Buyer may, at any time or from time to time, by written order specifically designated as a "Change Order," require changes within the general scope of the Contract. Vendor shall perform any such changes so ordered. The authority to order a change is limited to Buyer's Procurement Representative. Notwithstanding the existence or pendency of any claim for such an adjustment, Vendor shall diligently proceed with performance of the Contract, as directed by Buyer, and nothing herein shall be construed as relieving Vendor of its obligation to perform, including, without limitation, the failure of the parties to agree upon Vendor's entitlement to, or the amount of, any such adjustment. Failure to do so may be deemed a breach of contract. If Vendor interprets any Buyer communication as a Change Order, but the communication is not specifically designated as a "Change Order," Vendor must secure written confirmation before performing or lose the right to seek any equitable adjustment. Any disagreement between the Parties pursuant to this Article shall be resolved in accordance with the Disputes provision herein.

## **12. OPTION FOR INCREASED QUANTITY**

Unless this is an Indefinite Quantity Delivery type of contract, and if so provided in the Order Form, Buyer may increase the Goods and/or Related Services called for by the quantity and at the unit price(s) specified. Buyer may exercise this additional option by providing written notice to Vendor within the period of time stipulated in the Contract. Delivery of the additional Goods or performance of the additional Related Services, as applicable, shall be subject to the terms and conditions of the Contract, except as the Parties may otherwise agree in writing.



### **13. TERMINATION, SUSPENSION, AND OTHER REMEDIES**

- A. Buyer reserves the right to terminate this Contract in whole at any time, or in part from time to time, for its sole convenience. In the event of such termination, Vendor shall immediately stop all work hereunder and shall immediately cause any and all of its sub-vendors, suppliers and subcontractors (including the Manufacturer, if different from the Vendor) to cease work. Subject to the terms of this Contract and to reimbursement of Buyer by the Government, Vendor shall be paid a percentage of the total Contract Price reflecting the percentage of the work performed prior to the notice of termination, plus reasonable charges Vendor can demonstrate to Buyer's satisfaction using its standard record keeping system, have resulted from the termination. Vendor shall not be required to comply with the Cost Accounting Standards or contract cost principles for this purpose. Vendor shall not be paid for any work performed or costs incurred which reasonably could have been avoided.
- B. Buyer may also terminate the Contract at any time in whole, or from time to time in part, for cause in the event of default by Vendor (including, but not limited to, any default by Vendor's sub-vendors, suppliers or subcontractors, or by the manufacturer), or if Vendor fails to comply with any Contract term or condition, or fails to provide Buyer, upon request, with adequate assurances of future performance. In the event of termination for cause, Buyer shall not be liable to Vendor for any Goods or Related Services not already delivered, and shall have any and all of the other rights and remedies against Vendor provided by the Contract or by applicable law and regulation.
- C. If it is determined that Buyer improperly terminated the Contract for default, such termination shall be deemed a termination for convenience, and Vendor's rights and remedies shall be limited to those stated in Article 13,B. If the termination for default is not improper, in addition to the other rights and remedies provided by the Contract or by applicable law and regulation, Buyer may purchase elsewhere goods similar to those not yet delivered, and Vendor shall pay Buyer any costs that it incurs over the Contract Price (or relevant part thereof).
- D. If performance of the USAID Agreement is suspended for any reason, Buyer may, by written notice, instruct Vendor to immediately suspend all or any part of its performance. The period of suspension shall extend for up to ninety (90) days from the date of Vendor's receipt of the notice, and may be extended if, and to the extent that, the suspension of the USAID Agreement is extended. Before the end of the period, Buyer will either cancel the suspension or terminate the Contract pursuant to Paragraph A or B above. If the suspension is cancelled before it expires, or the suspension period expires without renewal, Vendor shall resume its performance. No additional compensation will be due to Vendor due to the suspension; however, if necessary, Vendor may propose an appropriate adjustment in the performance schedule. In the event of termination, the procedures in Paragraph A or B, as applicable, will be followed.
- E. Termination of the Contract shall not affect the existing rights and licenses granted to Buyer or the Government, which shall survive such termination.

- F. In the event that Vendor (or the Manufacturer, if Vendor is not also the manufacturer) shall cease conducting that portion of its business which produces, distributes or supports the Goods described herein, Buyer shall have, in order to fulfill its obligations to the Government, such rights to technical data, computer software and any other Vendor-provided information, documentation and materials used in connection with the Goods as are necessary for the continued performance of the USAID Agreement. Vendor shall assist Buyer and the Government in every reasonable manner in arranging for the orderly transfer, under such provisions stated herein, of all activities to Buyer or to the designees of either of the foregoing.
- G. Notwithstanding termination or suspension in accordance with this article, Vendor shall, unless otherwise specifically instructed in writing by Buyer, continue performance of any not terminated or not suspended portion of the Contract.

#### **14. LIQUIDATED DAMAGES**

The time fixed for delivery is the essence of the contract, and all damages for late delivery or any other form of non-compliance with the contract terms shall be strictly enforced. In the event of delay in performance, JSI reserves the right to retain as liquidated damages from any money due the Contractor an amount equal to five percent (5%) of the cost of the contract for every complete week of delay or a part thereof, reckoning from the time fixed by the contract. The total amount of the liquidated damages shall, however, be limited to ten percent (10%) of the value of the delayed contract.

#### **15. NOTICES**

- A. Contract notices shall be in writing; shall clearly reference the JSI Agreement Number; shall be manually signed by the notifying Party's authorized representative; shall be e-mailed as a PDF document, mailed postage prepaid or, if sent by recognized express courier, personally delivered; and shall, in all cases, be addressed to the individuals as identified on the Order Form.
- B. Contract notices transmitted by facsimile, telegram or telex may be provided as advance copies, provided that an identical copy is promptly transmitted in accordance with Paragraph A above. Notices shall be effective when received, or on the effective date stated in the notice, whichever is later.

#### **16. DISPUTES BETWEEN THE PARTIES ON MATTERS INVOLVING THE GOVERNMENT**

Notwithstanding any other provision of the Contract, any action by a cognizant Government official purporting to act within his/her authority under or in connection with the USAID Agreement or the present Contract that binds Buyer shall also bind Vendor if, and to the extent that, the action relates to or affects the Contract. If requested by Vendor in writing, Buyer may agree at Vendor's expense to sponsor a claim with Government. Vendor shall reimburse Buyer for all costs incurred by Buyer as a result of sponsoring such a claim, without charge to the Contract.

#### **17. DISPUTES**

- A. The Parties shall make every reasonable effort to resolve through discussion any dispute between them arising from, or relating to, the Contract. If such efforts are unsuccessful, either Party may refer the matter to arbitration, which shall be the exclusive method of resolving such disputes
- B. The arbitration shall be conducted in Boston, Massachusetts, under the supervision of the American Arbitration Association ("AAA") using its Commercial Arbitration Rules (if Vendor is a U.S. entity) or its International Arbitration Rules (if Vendor is a non-U.S. entity), as then in effect, before a single arbitrator appointed in accordance with such rules. The decision of the arbitrator will be in writing, and will contain a statement of reasons; the resulting award shall be final and binding on the Parties and shall be in lieu of any other remedy. Judgment may be entered upon the award in any court of competent jurisdiction.
- C. Notwithstanding the pendency of any arbitration proceeding, the Parties shall continue to perform their respective obligations pursuant to the Contract.

#### **18. BUYER'S DISPOSITION RIGHTS**

Vis-à-vis Vendor (or the manufacturer, if different from Vendor), Buyer and the Government shall have the right, in their sole discretion, to dispose of the Goods supplied under the Contract in any lawful manner including without limitation donation, use, resale, or re-export. Such disposition shall not require the approval or consent of Vendor, nor shall it be deemed to give rise to any claim by Vendor (or the manufacturer, if different from Vendor) against Buyer or the Government for compensation or otherwise of whatever nature. Buyer will notify Vendor before re-exporting the Goods outside of the Cooperating Countries.

#### **19. COMMUNICATIONS WITH GOVERNMENT**

All communications with the Government concerning the Contract or the Project of which the Contract is a part shall be made through Buyer unless otherwise expressly authorized by Buyer. If Vendor is called upon by the Government to communicate concerning the Contract or the Project, Vendor shall notify and consult with Buyer before responding.

#### **20. CONFIDENTIAL INFORMATION AND DISCLOSURE**

- A. Information which either Party may disclose to the other shall not be deemed to be "Confidential Information" and shall be acquired free from any restriction, unless the information is confidential and/or proprietary to the disclosing Party and:
  - [1] if it is disclosed in tangible form, the disclosing Party marks such information as "Proprietary," "Restricted" or "Confidential"; and
  - [2] if it is disclosed verbally, the disclosing Party expressly identifies such information as confidential at the time of disclosure and thereafter reduced to tangible form with a copy, prominently marked as aforesaid, delivered to the receiving Party within ten (10) days of the verbal disclosure.

When writing contains both Confidential Information and non-confidential information, the disclosing Party shall specifically note which information is deemed confidential.

- B. Each Party shall exercise the same degree of care to avoid the disclosure, publication or dissemination of the other Party's Confidential Information as it affords to its own Confidential Information of a similar nature which it desires not to be disclosed, published or disseminated. Confidential Information disclosed under the Contract shall only be used by the receiving Party in the furtherance of the Contract and the performance of its obligations hereunder.
- C. Neither Party shall be obligated to protect Confidential Information of the other which:
  - [1] is rightfully received by the receiving Party from another source without restriction;
  - [2] is known to or developed by the receiving Party independently without use of the confidential information;
  - [3] is or becomes generally known to the public by other than a breach of duty hereunder by the receiving Party;
  - [4] has been or is hereafter furnished by the disclosing Party to others without restriction on disclosure; or
  - [5] is known or available to the receiving Party by inspection or analysis of products available in the market.
- D. The obligation not to disclose, publish, disseminate or use said Confidential Information shall survive the cancellation, expiration, or termination of the Contract, and shall end five (5) years after the date of receipt of said Confidential Information, except with respect to any Software, for which the obligation shall continue until the occurrence of any of the events listed in Paragraph C, above.
- E. Nothing contained herein shall be construed as preventing Buyer from—
  - [1] sublicensing or marketing Software or documentation to the Government; or
  - [2] disclosing Confidential Information to its affiliated entities, third parties and others in furtherance of the USAID Contract; provided, however, that such affiliated entities, third parties and others agree to protect such information to the extent provided herein.
- F. Vendor hereby authorizes Buyer to incorporate Vendor's (and, if Vendor is not also the Manufacturer, the Manufacturer's) Confidential Information in submissions to the Government, on condition that it bears an appropriate restrictive legend.

## **21. INDEPENDENT CONTRACTOR**

The relationship between the Parties pursuant to the Contract is that of independent contractors, and nothing contained herein shall be deemed to create a relationship of partners, joint ventures, agent and principal, employer and employee, or any relationship other than that of independent

contractors. At no time shall either Party make any commitments or incur any charges or expenses for or in the name of the other Party.

## **22. GOVERNING LAWS, REGULATIONS, AND LANGUAGE**

- A. Vendor shall, in performing its obligations pursuant to the Contract, comply with all applicable statutes, rules, regulations, and executive orders of the Government (including without limitation the CFR and Standard Provisions), as well as all other applicable laws and regulations.
- B. The Contract, its making and performance, and the circumstances surrounding all of the foregoing, shall be interpreted in accordance with the laws of the State of Massachusetts in the U.S.A., without regard to its conflicts of law principles.
- C. The language governing the Contract, its interpretation, notices, disputes, and any related communications, shall be English.

## **23. GOVERNMENT-REQUIRED CERTIFICATIONS**

Vendor shall furnish to Buyer any certification required by any applicable law, or applicable USAID regulation or policy, in effect on the date the Contract is issued or thereafter enacted. As used in this Article, the word "certification" shall include, but not be limited to, any plan or course of action or record keeping function, representation or document of similar tenor.

## **24. PROBITY**

- A. Vendor shall strictly ensure that Vendor and its officers, directors, employees, agents, representatives, consultants and subcontractors avoid—
  - [1] any action in violation of (or that might reasonably be considered to be in violation of) U.S. Government or other applicable laws, regulations, rules and policies relating to ethics, integrity and proper business practices; and
  - [2] any corrupt practice (including without limitation the offering, giving, receiving or soliciting of anything of value to influence the action of any public official or any officer, employee or director of Buyer or Vendor) or fraudulent practice (including without limitation misrepresentation of facts to influence a procurement action or Contract execution or administration), to the actual or potential detriment of Buyer, the Government, or the Cooperating Countries.
- B. If an issue should arise concerning compliance with this Article, Vendor shall immediately provide Buyer with written notice describing the issue, all pertinent facts as known on the date of the notice, any conclusions reached by Vendor as of that date, and any corrective actions proposed. Failure to respond aggressively and appropriately to such issues may be treated by Buyer as a material breach of the Contract. Vendor shall indemnify and hold Buyer harmless for any costs, delays, losses, damages or other liabilities (including, but not limited to, reasonable costs and fees of attorneys and expert consultants and costs and fees incurred in connection with Government investigations)

incurred by Buyer as a result of any occurrences covered by this Article, or any allegations relating to purported occurrences of this nature.

## **25. INDEMNITIES**

- A. Vendor shall indemnify and hold harmless Buyer (including its officers, directors, employees and agents), The Hershey's Company, and the Government from and against all claims, damages, losses and expenses with respect to the death, injury or disability of any persons and damage to or destruction of any property (including without limitation any loss of use, and any product liability or similar claim, in or under the laws of any of the Cooperating Countries or other applicable law) arising out of, resulting from or connected in any way with the performance of the Contract by Vendor or Vendor's employees, the Manufacturer (if different from Vendor), other sub-vendors and subcontractors, or their respective officers, directors, employees and agents; provided, that the Goods are used and stored in a manner consistent with any manufacturer recommendations specifically noted by Vendor in its offer and expressly incorporated by Buyer into the Contract.
- B. Vendor shall, at its own expense, defend all suits or claims (whether or not false, fraudulent or groundless) by third parties alleging such injury or damage and shall pay all reasonable charges of attorneys, court costs, awards and all other costs and expenses in connection therewith. This provision shall survive the cancellation, expiration or termination of the Contract.
- C. Vendor shall indemnify Buyer (including its officers, directors, employees and agents), The Hershey's Company, and the Government against liability, including costs, for actual or alleged direct or contributory infringement of, or inducement to infringe, any U.S. or foreign patent, trademark, or copyright, arising out of the performance of the Contract; provided that Vendor is reasonably notified of such claims and proceedings.
- D. Buyer shall give Vendor prompt written notice of—
- [1] any claim by a third party, or
  - [2] any action or proceeding (including without limitation any Government investigation or inquiry) potentially involving one of the indemnities set forth above. Upon receipt of such notice, Vendor shall promptly assume the defense thereof, including the employment of counsel reasonably satisfactory to Buyer, and shall be solely responsible for the payment of all fees and expenses incurred in connection with such defense. Notwithstanding the foregoing, Vendor shall not, without Buyer's approval, consent to entry of any judgment or enter into any settlement which does not include as an unconditional term thereof the giving by the claimant or plaintiff a release, in form and substance satisfactory to Buyer, from all liability with respect to such claim or litigation.

## **26. RELEASE OF INFORMATION**

Any Vendor news release, public announcement, advertisement or publicity concerning the Contract or the USAID Agreement will be subject to prior written approval of Buyer. Vendor shall not disclose any information relating to the Contract to any person not authorized by Buyer or the Government to receive it.

## **27. GRATUITIES**

Vendor shall ensure that Vendor, Manufacturer (if different from Vendor), and Vendor's sub-vendors and subcontractors if any, and their respective officers, directors, employees and agents, comply with the requirements of 2CFR200.318(c)(1). For purposes of this clause, in connection with the Contract, prohibited recipients of gratuities include not only employees of the Government, but of Buyer as well.

## **28. CONFLICT OF INTEREST**

The Vendor agrees that there is no conflict of interest in accepting the contract which might affect the ability to provide fair and useful service and deliverables on behalf of JSI or USAID.

## **29. NOTICE OF DELAY OR IMPEDIMENT**

Whenever any occurrence is delaying or impeding, or threatening to delay or impede, Vendor's timely and successful performance under the Contract, Vendor shall promptly give notice thereof, including all relevant information with respect thereto, to Buyer.

## **30. EXCUSABLE DELAYS**

The Vendor shall be liable for default unless nonperformance is caused by an occurrence beyond the reasonable control of the Vendor and without its fault or negligence such as, acts of God or the public enemy, acts of the Government in either its sovereign or contractual capacity, fires, floods, epidemics, quarantine restrictions, strikes, unusually severe weather, and delays of common carriers. The Vendor shall notify JSI in writing as soon as it is reasonably possible after the commencement of any excusable delay, setting forth the full particulars in connection therewith, shall remedy such occurrence with all reasonable dispatch, and shall promptly give written notice to JSI of the cessation of such occurrence.

## **31. RETURN UPON COMPLETION**

Upon completion of performance of the Contract, on request, Vendor shall promptly return to Buyer all Specifications, plans, drawings, patterns or samples - - and all copies of any of the foregoing. All of the items referred to in the preceding sentence shall be and remain, at all times, Buyer's sole property.

## **32. ADDITIONAL PROVISIONS INCORPORATED BY REFERENCE**

This contract is funded under JSI's Cooperative Agreement (i.e., the SPRING Project) with USAID. As required in the SPRING Cooperative Agreement, all contracts and procurement funded under this award are subject to applicable provisions required to flow down from the Cooperative Agreement, including USAID's Standard Provisions for U.S. Non-Governmental Organizations (NGOs) and Appendix II to 2 CFR 200, Contract Provisions for Non-Federal Entity Contracts Under Federal

Awards. A list of these provisions can be found on the SPRING Intranet Procurement Page: <https://www.spring-nutrition.org/spring-procurement> as a downloadable document, and these provisions are hereby incorporated into this contract by reference.

### **33. EXECUTIVE ORDER ON TERRORIST FINANCING**

The contractor must not engage in transactions with, or provide resources or support to, individuals and organizations associated with terrorism, including those individuals or entities that appear on the Specially Designated Nationals and Blocked Persons List maintained by the U.S. Treasury (online at: <http://www.treasury.gov/resource-center/sanctions/SDN-List/Pages/default.aspx>) or the United Nations Security designation list (online at: [http://www.un.org/sc/committees/1267/aq\\_sanctions\\_list.shtml](http://www.un.org/sc/committees/1267/aq_sanctions_list.shtml)).

### **34. DEBARMENT, SUSPENSION, INELIGIBILITY, AND VOLUNTARY EXCLUSION**

The Contractor certifies that neither it nor its principals is presently excluded or disqualified from participation in this transaction by any US Government federal department or agency.

### **35. DEFINITIONS OF TERMS**

When used in the Contract, the following terms, whether or not capitalized, shall have the meanings indicated:

- A. Amendment means a writing signed by the Parties, designated as an "Amendment" and sequentially numbered, modifying the provisions of the Contract;
- B. Associated Services means Services that are not separately priced in the Contract, but rather are deemed to be included in the Prices of the Goods with which they are associated;
- C. Buyer means JSI Research & Training Institute, Inc. (JSI), acting on behalf of USAID;
- D. Buyer's Procurement Representative means the individual natural person, designated as such by Buyer with written notice to Vendor;
- E. Contract means all the documents listed in Article 2 of the Contract Form, as amended from time to time.
- F. Cooperating Country means the country or countries in which Goods will be distributed and/or Services provided, as listed in the Contract Form;
- G. Delivery means goods delivered in accordance with the applicable term as defined by Incoterms 2000, as modified by the Contract.
- H. Goods means all items (including, but not limited to, supplies, equipment, parts, materials), together with all Associated Services that are not separately priced on



the Contract, described in the Contract and strictly conforming in all respects to the requirements of such Contract;

- I. Government means the U.S. Government (unless otherwise stated, represented by the U.S. Agency for International Development), acting in its contractual capacity;
- J. Order Form means a Purchase Order, an Order Form for a Firm Fixed Price Contract, or a Delivery Order;
- K. Party means either Buyer or Vendor individually (collectively, the "Parties");
- L. Pharmaceutical means any substance intended for use in the diagnosis, cure, mitigation, treatment or prevention of diseases in humans or animals; any substances (other than food) intended to affect the structure or any function of the body of humans or animals; and, any substance intended for use as a component in the above. The term includes drugs, vitamins, oral rehydration salts, biologicals, and some in-vitro diagnostic reagent/test kits; but does not include devices or their components, parts, or accessories;
- M. Price, except as may otherwise be specifically stated, means the Total Contract Price stated on the Order Form (covering all Goods described on the Order Form, all Associated Services necessary to perform Vendor's obligations pursuant to the Contract, and any Related Services, together with the prices of all Goods included in any option exercised pursuant to Article 11;
- N. Related Services means services (if any) specifically described and priced separately from the Goods as a Line Item on the Order Form;
- O. Unit Price means the price indicated in the Order Form covering, as applicable, [a] each item of the Goods, along with any Associated Services, or [b] Related Services;
- P. USAID means the U.S. Agency for International Development;
- Q. USAID Agreement means Cooperative Agreement AID-OAA-A-11-00031 between USAID and Buyer (as modified from time to time); and
- R. Vendor means the legal entity to which the Contract is issued.

### **36. OFFSETS**

- A. At any time, or from time to time, Buyer reserves the right to deduct, or cause to be deducted, from any payment(s) otherwise due to Vendor, whether in connection with the Contract or any other agreement, all or any part of any amount that Buyer determines is owed to Buyer by Vendor.

- B. Buyer will use this authority cautiously and fairly, providing advance written notice and an opportunity to comment whenever doing so is deemed practicable in Buyer's sole discretion. If prior notice is deemed impracticable, Buyer will give notice subsequently.

### **37. NON-WAIVER**

Buyer's failure to insist, in any one or more instances, upon the performance of any of the terms, covenants or conditions of the Contract or to exercise any right hereunder, shall not be construed as a waiver of the future performance of any such term, covenant or condition or the future exercise of such right.

### **38. SEVERABILITY**

If any provision of the Contract is determined by a court of competent jurisdiction to be invalid or unenforceable, the remaining provisions shall continue in full force and effect as if the Contract had been executed with the affected provision eliminated.

### **39. SURVIVAL OF PROVISIONS**

In addition to the rights and obligations which survive as expressly provided for elsewhere in the Contract, the other provisions which by their nature should survive shall survive and continue after any termination or cancellation of the Contract.

### **40. ASSIGNMENT**

Vendor shall not assign or transfer, in whole or in part, any of its rights or duties under the Contract, or any of the monies due or to become due hereunder, without Buyer's prior written consent. Any assignment or transfer entered into by Vendor without such consent shall be null and void as against Buyer unless thereafter ratified by Buyer in writing.

Buyer may, at its sole discretion, assign the Contract, and any or all rights, obligations and claims thereunder or relating thereto, to the Government, at any time or from time to time during the Contract Term, without Vendor's consent but with written notice to Vendor.

### **41. LIMITATION ON DAMAGES**

If a claim for damages or a right to any other form of relief, based on contract, indemnity, negligence or otherwise should arise in connection with the Contract, the claiming Party shall take all necessary measures to mitigate the damages or loss, to the extent that this can be accomplished without unreasonable cost or inconvenience. In no event shall any such claim or relief include or permit recovery of exemplary or consequential damages, however described.

### **42. EXCLUSIVE AGREEMENT**

The Contract is the exclusive agreement between Buyer and Vendor pertaining to the subject matter hereof. It supersedes all prior agreements, understandings, communications, negotiations and

discussions, whether oral, written or electronic. No purported trade usage, custom, course of dealing or verbal statements of any kind shall be binding on Buyer.

**43. VENDORS WHO ARE NOT THE MANUFACTURERS OF THE GOODS**

Vendors who are not also the Manufacturers of the Goods being supplied shall fully comply with the requirements of the Contract themselves. In addition, they shall also be responsible for requiring the actual Manufacturers to comply to the extent specified in the Contract or otherwise as necessary to ensure Vendors' own compliance.

## ANNEX 6: SPECIAL CONTRACT TERMS AND CONDITIONS FOR THE PROVISION OF RELATED SERVICES

---

If the Contract calls for performance of Related Services overseas by Vendor employees or consultants (collectively, Vendor "personnel"), Vendor shall comply with the following requirements:

1. Vendor shall notify Buyer (sufficiently in advance to permit Buyer to notify USAID and obtain its concurrence if needed) of any planned travel overseas by its personnel. Such notice shall include the number and names of the personnel participating, the proposed itinerary and logistics arrangements, and the Services to be provided, along with the information specified in AIDAR 752.7004, EMERGENCY LOCATOR INFORMATION (JULY 1997).
2. Vendor shall ensure that its personnel, while in a Cooperating Country, abide by all applicable laws of the Cooperating Country and political subdivisions thereof.
3. Other than work performed under the Contract for which they are assigned, Vendor personnel shall not engage, directly or indirectly, either in their own name or in the name (or through the agency) of another person, in any business, profession or occupation in the Cooperating Country, nor shall they make loans or investments to or in any business, profession or occupation in the Cooperating Country, without Buyer's prior written approval. This provision does not apply to Vendor personnel who are citizens or legal residents of the Cooperating Country.
4. Vendor shall obtain (1) workers' compensation (Defense Base Act) insurance pursuant to FAR 52.228-3 (APRIL 1984) and AIDAR 752.228-3, and (2) medical evacuation (MEDEVAC) insurance pursuant to AIDAR 752.228-70 ( Mar 1993) as modified by USAID Acquisition and Assistance Policy Directive 06-01 (text available at [http://www.USAID.gov/business/business\\_opportunities/cib/pdf/aapd06-01.pdf](http://www.USAID.gov/business/business_opportunities/cib/pdf/aapd06-01.pdf)) for personnel traveling to a Cooperating Country in connection with this Contract.
5. Vendor personnel traveling on Vendor's behalf shall possess appropriate language skills, if any, stated in the Contract, and shall be physically fit in accordance with AIDAR 752.7033 (JULY 1997)
6. Vendor shall comply with USAID guidance, if any, relating to branding/marketing of activities (see <http://www.USAID.gov/branding/>).
7. FAR 52.246-4, INSPECTION OF SERVICES - - FIXED-PRICE (AUG 1996) shall apply to Related Services.
8. If the Related Services involve the creation of any copyrightable materials, such materials shall be deemed to constitute "works made for hire" under the Copyright Act of 1976 unless otherwise stated in the Order Form or otherwise agreed to in writing by Buyer.
9. All logistics support, visas, legal compliance matters and taxes in connection with its personnel overseas shall be the sole responsibility of Vendor, as will all liability for the acts and omissions of Vendor personnel. Vendor shall indemnify and hold Buyer harmless for all costs (including

reasonable attorney's fees) incurred by Buyer in relation to the matters covered by this paragraph.

10. Compensation for satisfactory performance shall be paid upon completion thereof in compliance with the terms and conditions of the Contract and solely in the form of the firm, fixed, all-inclusive prices specified in Article 5 [the Order Form??].
11. Notwithstanding any other provision of this Contract, no additional compensation or reimbursement will be provided to Vendor for complying with the foregoing requirements.

## ANNEX 7: SPECIAL CONTRACT TERMS AND CONDITIONS - LIQUIDATED DAMAGES FOR DELAY

---

Vendor acknowledges the urgent need for the Goods, as well as the difficulty of ascertaining at the time of contracting the precise nature and amount of actual damages that Buyer will suffer in the event of any delay in Vendor's performance.

In view of the foregoing, if Vendor fails

- (1) to make the Goods available for inspection and testing,
- (2) to deliver the Goods, or
- (3) to complete performance of the Related Services, in strict compliance with the terms of the Contract, by the date(s) specified in the Order Form, the Buyer may, in addition and without prejudice to any of its other rights or remedies under the Contract (or otherwise available at law or in equity), deduct from any payment(s) due or to become due to Vendor, under or in connection with this or any other agreement between the Parties, as liquidated damages, the amounts agreed upon and set forth in the Order Form. The Parties agree that these amounts represent a reasonable estimate of the actual damages anticipated at the time of contracting, and confirm that these amounts have been specifically negotiated and mutually agreed upon.

Once the maximum deduction has been reached, Buyer may, in addition and without prejudice to any other termination right set forth in the Contract, terminate this Contract for default without any further liability on its part (in which case Buyer may retain or collect, as applicable, the liquidated damages). In the event of timely or compliant delivery of partial quantities, Buyer may, in its reasonable discretion, reduce the periodic or total deduction to the extent it deems appropriate.

Notwithstanding the imposition of liquidated damages in accordance with this Paragraph, Vendor shall proceed with delivery and performance of its obligations pursuant to the Contract unless otherwise instructed or approved in writing by Buyer.

## ANNEX 8: SPECIAL CONTRACT TERMS AND CONDITIONS FOR QUALITY ASSURANCE TESTING AND INSPECTION

---

A. Buyer shall have the right to sample, inspect, and test the Goods at the time(s) and location(s) indicated in the Order Form. In addition, Buyer shall have the right to sample, inspect, and test Pharmaceuticals in course of their manufacture and packaging.

B. Vendor shall provide all reasonable facilities for such sampling, inspection and testing at no cost to Buyer.

C. Buyer will use its best efforts to complete sampling, testing and inspection as promptly as possible after the Goods are made available.

D. Buyer may, at its sole discretion

(1) require Vendor to repair or replace any nonconforming Goods, or re-perform of any nonconforming Services, at no increase in the Contract Price, and with all additional costs, including those arising from the handling and disposition of the non-conforming Goods and the sampling, inspection and testing of replacement Goods, for the account of Vendor; and/or

(2) exercise any other rights and remedies available to it under the Contract, or under applicable law and regulation, including, but not limited to, termination of the Contract, call of performance security, and/or assessment of excess re-procurement and other resulting costs.

Buyer will use its best efforts to exercise the foregoing rights within a reasonable time after non-conformity is discovered and, to the maximum extent practicable, before any substantial change occurs in the condition of the non-conforming Goods, unless such change is due to their non-conformity.

If/when deemed necessary and appropriate, Buyer may by written notice to Vendor require pre-delivery sampling, inspection and testing of the Goods including, without limitation, physical inspections of the production, warehousing and other facilities involved, the product packaging and labeling; inspection and review of manufacturing records, Certificates of Analysis, analytical reports and documentation; and product sampling and testing by an independent testing facility. In such cases, Vendor will cooperate fully with Buyer, the Sampling Agent and the testing facility and take such steps and supply such information as may be needed in order to ensure timely and effective quality assurance.

Only Goods that have successfully passed testing may be deemed to be ready for delivery in accordance with SCTC Article 5.

Buyer may also direct post-delivery sampling, testing, and/or inspection of the Goods at any point in the chain of supply and distribution when it deems such action to be in the best interests of the Government. Vendor will fully cooperate with such measures as well. Prompt removal and replacement or correction (as applicable), shall be deemed, unless otherwise subsequently agreed by Buyer, to mean (10) business days after receiving notification of rejection of Goods or Services.